



"Little Wonder"



DIVISION OF SCHILLER-PFEIFFER, INCORPORATED

1028 STREET ROAD, P.O. BOX 38

SOUTHAMPTON, PA 18966

AREA CODE 215-357-5110

FAX #215-357-8045

OPERATING INSTRUCTIONS FOR LITTLE WONDER PRODUCTS WITH ECHO MODEL SV 4 TWO CYCLE ENGINES

FUEL AND LUBRICATING OIL (engine only)

Your Little Wonder 2 cycle fuel powered product is equipped with an Echo Model SV 4, two stroke, air cooled engine which requires a fuel mixture of gasoline and lubricating oil.

The approved fuel to oil ratio is 32 parts gasoline, either regular or unleaded to 1 part of Echo approved oil, (32:1), or 20 parts gasoline, either regular or unleaded to 1 part oil when using another reputable 2-cycle air cooled engine oil, (20:1). The oil and gasoline should be thoroughly mixed in a clean container. **DO NOT ATTEMPT TO MIX IN FUEL TANK.** Pour half the gasoline into the container, add the oil and shake to insure thorough mixing. Add the remainder of the gasoline and shake once again. The fuel tank capacity is 17.5 fluid ounces or 1.1 pints.

CAUTION

The clutch engagement speed is 3300 to 3400 RPM, approximately; therefore, the unit will function at fast idle.

(NOTE) Recoil starter: Use short pulls - only 1/2-2/3 of starter rope for starting. Always hold the unit firmly with both hands.

1. STARTING THE ENGINE COLD

- a. Be sure that the fuel tank is filled with the correct mixture of gasoline and 2 stroke oil.
- b. Switch the ground switch to the "START" position.
- c. With the choke completely closed, pull the starter rope three to five times with short pulls. This draws fuel into the firing chamber.
- d. Push the choke lever all the way in (To open choke completely.)
- e. Pull the recoil starter rope smoothly and quickly until the engine fires.
- f. If the engine stops, close the choke and pull on the starter rope twice; then open the choke, pull the starter rope until the engine starts and continues to run.

2. STARTING THE ENGINE HOT

- a. Switch the ground switch to the "START" position.
- b. Pull the recoil starter rope smoothly and quickly until the engine runs.
- c. Follow the procedure for starting a cold engine after the engine has been left stopped for half an hour or more.
- d. After starting the engine by using the choke, adjust the choke as soon as the first explosive roar is heard.
- e. If the engine does not fire after a few pulls, squeeze the throttle to fast idle and try again.
- f. If it still does not start, check the plug.
- g. In the event that the engine has run out of fuel, it may be necessary after refueling to pull the recoil starter 8-10 times in order that the fuel pump can prime the carburetor.

3. STOPPING THE ENGINE

The engine will normally be stopped by moving ground switch to the "STOP" position. In an emergency, should the switch fail to stop the engine, pull the choke to the closed position and the engine will stall.

STEPS TO BE TAKEN DURING OPERATION

- 1) After starting, idle the engine for 3-5 minutes for warm up.
- 2) After idling, gradually open the throttle and the unit will start to operate as the engine revolution reaches approximately 3300 to 3400 RPM.
- 3) The engine keeps on running even when unit has stopped due to an excessive load. In such cases, remove the load and allow time for the unit to reach the specified speed before resuming the job. In the event that the unit gets stuck due to an overload, reduce the engine speed to idle, remove the obstruction and resume the work by squeezing the throttle lever.

ADJUSTING THE CARBURETOR

The carburetor has been adjusted at the factory for optimum performance. Should the carburetor require adjusting, this adjustment should be done by a qualified servicing dealer or mechanic.

To adjust the carburetor, proceed as follows:

- Low-speed needle valve (L) $1 \pm \frac{1}{4}$ turn
- High-speed needle valve (H) $1 \pm \frac{1}{4}$ turn

Turn the corresponding adjusting screw lightly clockwise to fully closed position and return the screw by the number of turns indicated above.

Lower the throttle lever and idle the engine for 3-5 minutes to cool it off. Then, stop the engine by moving the switch to the stop position.

The switch and the engine are connected by a grounding lead wire, to ensure the functioning of the switch. If the switch doesn't work properly, check the grounding wire connection.

STORING

If unit is to be stored for a long period of time, drain fuel completely from tank. Fuel stored under the most ideal conditions may start to go stale in 30 days. Stale fuel has a high gum content which can clog carburetor and restrict the fuel flow.

Start engine and allow to run until it stops. Choke and restart engine to make sure all fuel has been used from the carburetor. This prevents formation of gum deposits. Remove the spark plug. Pour about a teaspoonful of clean oil through the spark plug hole into the combustion chamber. Pull the starter handle slowly at least twice. This will coat the interior of the combustion chamber with oil. Clean, gap, and replace spark plug.

IGNITION SPARK PLUG

Clean or replace the plug if fouled with oily black deposits. Replace the plug if the center electrode is rounded at the end, or if the ground electrode is worn. Adjust the gap 0.6-0.7mm (.024-.028"). CAUTION — Do not over tighten the plug. Correct torque = 18-22 lbs. ft.

CAUTION

DO NOT ATTEMPT TO REMOVE THE PLUG FROM A HOT ALUMINUM CYLINDER HEAD IN ORDER TO AVOID POSSIBLE DAMAGE TO THE THREADS.

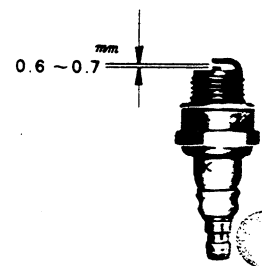

AIR FILTER

The performance, lubrication and temperature of the two stroke engine is seriously affected by a choked air filter. It is strongly recommended, therefore, that the filter should be cleaned every time the unit is used. Dust and dry dirt are readily removed from the filter element which can be washed in kerosene if necessary to remove oil accumulation.

SV-4 No. 1

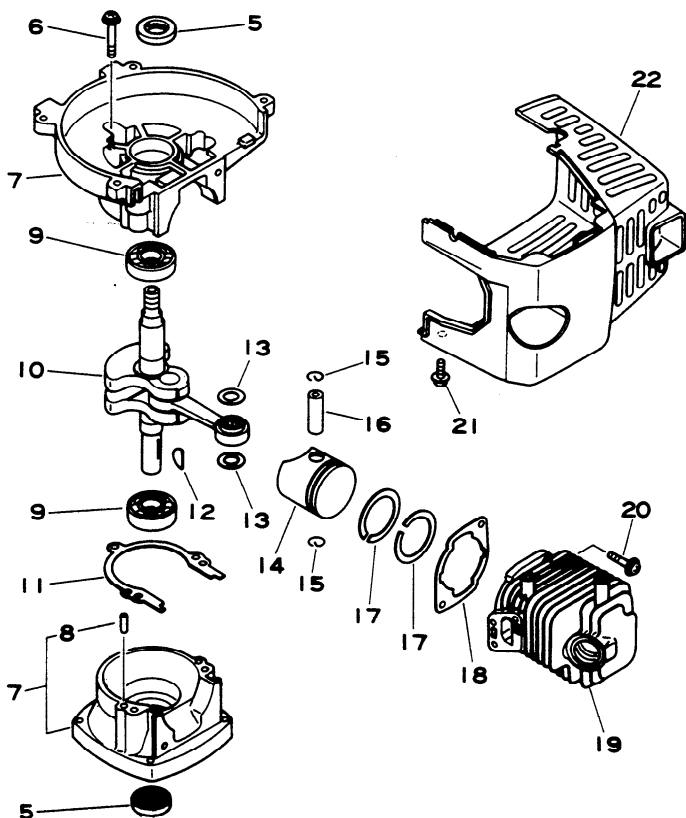

KEY NO.	PART NUMBER	QTY.	DESCRIPTION
1	5	2	OILSEAL
	6	3	SCREW SMB-5X28
	7	1	CRANKCASE SET
	8	2	PIN, DOWEL
	9	2	BEARING, BALL 6201
	15	2	CIRCLIP, PIST. PIN
	16	1	PIN, PISTON
	17	2	RING, PISTON
	*18	1	GASKET, CYL. BASE
	19	1	CYLINDER
	10	1	CRANKSHAFT ASSY
	*11	1	GASKET, CRANKCASE
	12	1	KEY, WOODDRUFF
	13	2	SPACER, PISTON PIN
	14	1	PISTON
	20	2	SCREW SMB-5X2
	21	2	SCREW 4X8
	22	1	COVER, CYLINDER
	889 000-4203 0	1	GASKET KIT
	1-18	1	GASKET, CYL. BASE
	1-11	1	GASKET, CRANKCASE
	*2-5	1	GASKET, INSULATOR
	*2-9	1	GASKET, CARBURETOR
	*2-26	1	GASKET, MUFFLER LTD.

* Available separately or in kit.

SV-4 No. 5

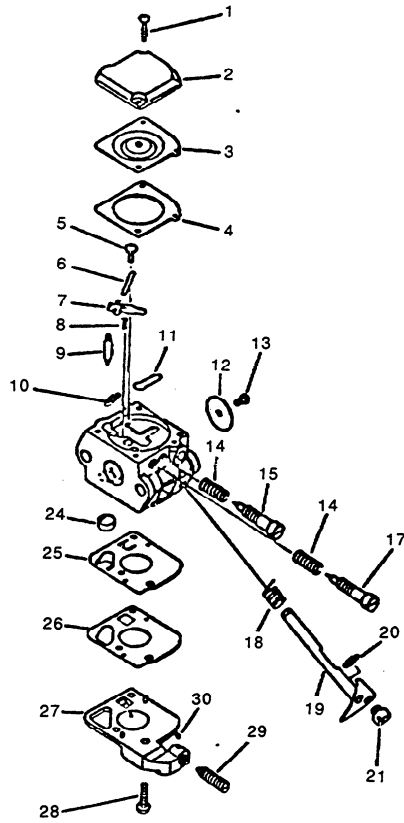

KEY NO.	PART NUMBER	QTY.	DESCRIPTION
5	125 200-1152 0	1	CARBURETOR
1	-125 344-1393 1	2	SCREW, METERING COVER
2	-125 342-1152 0	1	COVER, DIAPHRAGM
3	A.B.	0	DIAPHRAGM ASSY
4	A.B.	1	GASKET, METERING
5	-125 339-4203 0	1	SCREW
6	B	1	PIN, ARM
7	B	1	LEVER, METERING CHAM
8	B	1	SPRING, COIL
9	B	1	VALVE, NEEDLE
10	-125 327-1513 0	1	CLIP
11	B	1	PLUG, WELCH
12	-125 316-4203 0	1	VALVE, THROTTLE
13	B	1	SCREW
14	-125 319-4203 0	2	SPRING, COIL
15	-125 320-4203 0	1	NEEDLE, HIGH SPEED
17	-125 318-4203 0	1	NEEDLE, IDLE
18	-125 313-4203 0	1	SPRING, THRT, RETURN
19	-125 317-4203 0	1	SHAFT, THROTTLE
20	-125 327-1393 0	1	CLIP
21	-125 372-4203 0	1	SWIVEL
24	B	1	STRAINER
25	A.B.	1	DIAPHRAGM, FUEL PUMP
26	A.B.	1	GASKET, FUEL PUMP
27	-125 324-4203 0	1	COVER, PUMP
28	-125 310-4203 0	2	SCREW
29	-125 334-1393 0	1	SCREW, IDLE ADJUST
30	-125 378-1393 0	1	PIECE, FRICTION

A: Use 125303-42030 CARBURETOR
DIAPHRAGM/GASKET KIT.
B: Use 125302-42030 CARBURETOR REPAIR
KIT.

SV-4 No. 2

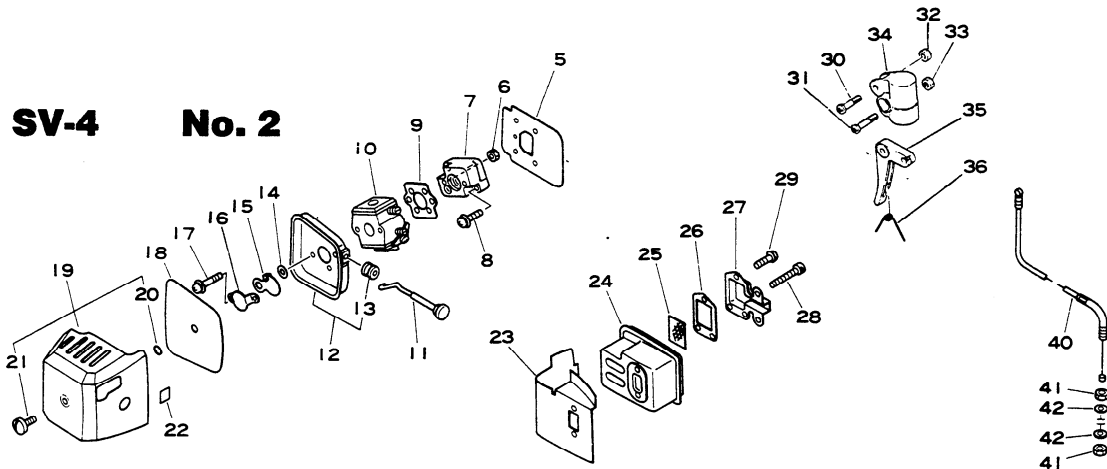

KEY NO.	PART NUMBER	QTY.	DESCRIPTION	
2	5	130 010-4203 0	1	GASKET, INSULATOR
6	900 500-0000 5	2	NUT 5	
7	130-017-4203 0	1	INSULATOR	
8	900 238-0502 0	2	SCREW SMB 5X20	
9	130 016-4203 0	1	GASKET, CARBURETOR	
10	125 200-1152 0	1	CARBURETOR	
11	178 510-0456 0	1	ROD, CHOKE	
12	130-301-0456 0	1	CASE, AIR CLEANER	
13	178 810-0523 0	1	BUSHING	
14	178 516-0083 0	2	SPACER	
15	178 515-0456 0	1	SHUTTER, CHOKE	
16	130 410-4473 0	1	BRACKET, AIR CLEANER	
17	900 242-0505 7	2	SCREW 5X57	
18	130 310-0456 0	1	FILTER, AIR	
19	130 302-1152 0	1	COVER ASSY, AIR CL	
20	-900 720-0000 4	1	O-RING (P-4)	
21	-130 415-4063 0	1	SCREW	
22	890 121-1233 1	1	LABEL, CHOKE	
23	145 871-1152 0	1	COVER, MUFFLER	
24	145 810-1152 0	1	MUFFLER	

KEY NO.	PART NUMBER	QTY.	DESCRIPTION
25	145 862-4063 0	1	SCREEN, MUFFLER
26	145 866-4203 0	1	GASKET, MUFFLER LID
27	145 815-1152 0	1	HOLDER, SCREEN (A)
28	900 105-0505 5	2	BOLT, H.S. 5X55
29	900 242-0401 0	3	SCREW 4X10
30	900 220-0502 8	1	SCREW 5X28
31	900 220-0502 5	1	SCREW 5X25
32	433 020-0083 0	1	LOCKNUT 5
33	900 500-0000 5	1	NUT 5
34	178 024-0613 0	1	BRACKET, THROTTLE
35	178 010 0533 0	1	CONTROL, THROTTLE
36	178 043 0523 0	1	THROTTLE, RET. SPRING
40	178 001-1152 0	1	CULTIVATOR, THROTTLE CABLE
40	178 002-1152 0	1	HEDGE CLIPPER, THROTTLE CABLE
41	900 502-0000 6	2	NUT 6 (3N)
42	900 602-0000 6	2	WASHER 6

KEY NO.	PART NUMBER	QTY.	DESCRIPTION
4	5	131 600-0452 0	1 CAP ASSY, FUEL (BL)
	6	-890 154-1513 0	1 LABEL, FUEL MIX
	7	-131 314-0033 0	1 VALVE, CHECK
	8	-131 015-0452 0	1 HOLDER, CHECK VALVE
	9	-131 016-0493 0	1 GASKET, F. TANK CAP
	10	131 005-1152 0	1 TANK, FUEL
	11	132 010-1152 0	1 PIPE, FUEL 3X5XL210
	12	132 115-0492 0	1 GROMMET
	13	132 013-0982 0	1 CLIP
	14	131 205-0732 0	1 STRAINER, FUEL
	16	900 250-0501 4	3 SCREW 5X14
	17	900 603-0000 5	3 WASHER 5

SV-4 No. 4

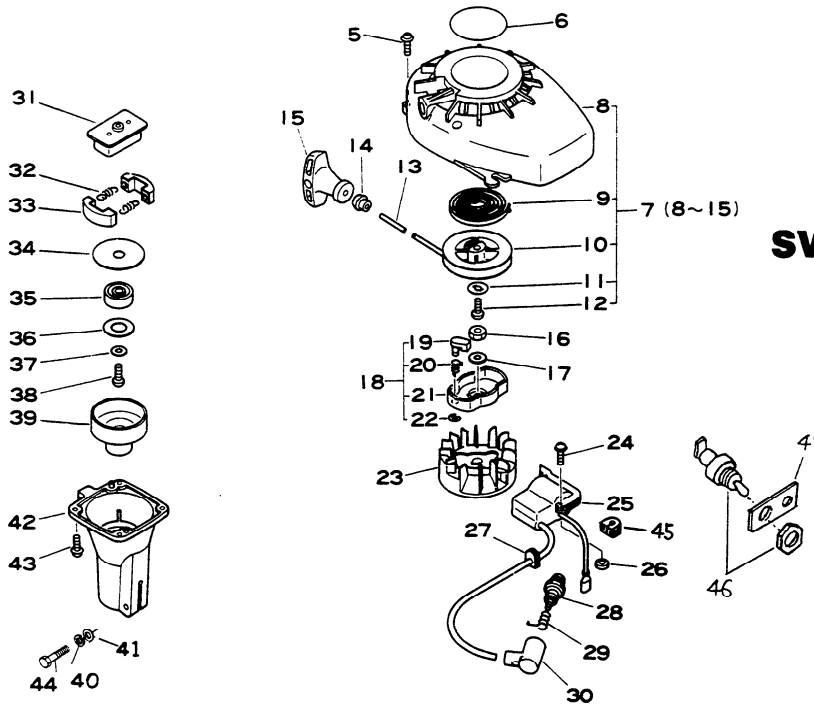
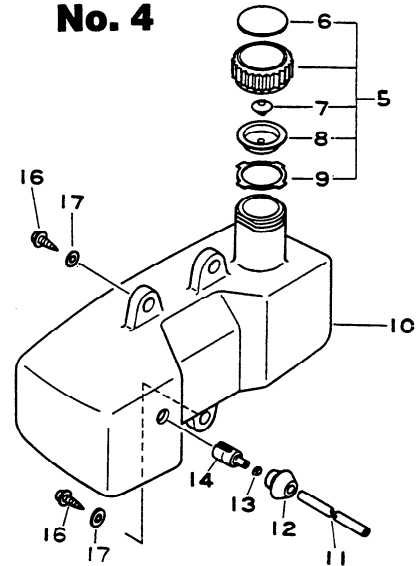

SV-4 No. 3

KEY NO.	PART NUMBER	QTY.	DESCRIPTION	KEY NO.	PART NUMBER	QTY.	DESCRIPTION
3	5	900 242-0401 6	4 SCREW, 4x16	26	150 117-0913 0	2	SPACER
	7	177 200-1152 0	1 STARTER ASSY.	27	152 112-0733 1	1	BUSHING
	8	-101 511-1152 0	1 COVER, FAN	28	159 010-1233 0	1	PLUG, SPARK (CJ-8Y)
	9	177 220-4203 0	1 SPRING, REWIND	29	159 011-0343 2	1	COIL, SPARK PLUG CAP
	10	-177 215-4203 0	1 DRUM, STARTER	30	159 012-0162 0	1	CAP. SPARK PLUG
	11	-177 214-4203 0	1 WASHER	31	175 016-0502 0	1	HUB, CLUTCH
	12	-177 236-1141 0	1 SCREW	32	175 018-0513 0	2	SPRING, CLUTCH
	13	-177 226-0553 0	1 ROPE, STARTER	33	175 009-0513 0	2	SHOE, CLUTCH
	14	-177 227-4203 0	1 GUIDE, ROPE	34	175 019-0463 0	1	PLATE, CLUTCH
	15	-177 228-1152 0	1 GRIP, STARTER	35	900 802-0600 0	1	BEARING, BALL 6000
	16	900 500-0000 8	1 NUT 8	36	175-044-0463 0	1	WASHER, CLUTCH
	17	900 600-0000 8	1 WASHER 8	37	175 014-0463 0	1	WASHER, CLUTCH
	18	177 202-4203 0	1 CATCHER ASSY, PAWL	38	900 238-0601 2	1	SCREW 6X12
	19	-177 218-4203 0	1 PAWL, STARTER	39	175 010-0463 2	1	DRUM, CLUTCH
	20	-177 234-4203 0	1 SPRING, RETURN	40	900 605-0000 5	1	SPRING WASHER 5
	21	-177 210-4203 0	1 CATCHER, PAWL	41	900 600-0000 5	1	WASHER 5
	22	-900 700-0000 6	1 E-RING 6	42	610 223-1152 0	1	CASE, CLUTCH (AR)
	23	150 801-4433 0	1 FLYWHEEL	43	900 238-0401 4	2	SCREW SMB-4X14
	24	900 238-0402 2	2 SCREW SMB-4X22	44	900 100-0502 5	1	SCREW 5X30
	25	150 626-1152 0	1 COIL, IGNITION	45	156 114-0492 0	1	GROMMET
				46	163 400-0216 0	1	SWITCH, IGNITION
				47	163 810-1152 1	1	BRACKET, SWITCH (HEDGE CLIPPER ONLY)

ECHO INCORPORATED

LITTLE WONDER PRODUCTS NINETY DAY LIMITED WARRANTY

Echo Incorporated, referred to hereafter as Echo, warrants to the original purchaser at resale that each new Little Wonder product shall be free from defects in material and workmanship for a period of ninety (90) days from the date of the original purchase. In the event a defect in a Little Wonder product, Echo will repair and/or replace the defective part or parts free of charge.

In the event of a malfunction or failure in a Little Wonder product simply deliver or send postage prepaid within the warranty period of ninety (90) days, the complete Little Wonder product to your nearest authorized Echo dealer. Echo reserves the right to inspect the claimed defective part or parts to determine if the defect or malfunction complained of is covered by this warranty. Upon confirmation that the malfunction or failure is the result of a defect covered by this warranty, Echo shall, within ninety (90) days after receipt of the product, at its option, repair and/or replace the defective part or parts free of charge.

Authorized Echo dealers are located throughout the United States and Canada to assure fast and efficient service to your Little Wonder product. If you do not know the location of an authorized Echo dealer, you can obtain such information by contacting Echo at the address listed below. Echo assumes no responsibility for any damage, defects, or costs resulting from repairs and/or modifications of an Echo product performed by any person who is not an authorized Echo servicing dealer or distributor.

This warranty shall only cover defects arising under normal usage. Echo assumes no responsibility whatsoever if the Little Wonder product shall fail during the warranty period by reason of:

1. Misuse, negligence, physical damage or accident.
2. Lack of maintenance as prescribed in the Owner's Manual.
3. Improper adjustments of ignition, timing and carburetors.
4. The use of fuels and lubricating oils not approved by Echo.
5. The use of parts or accessories not approved by Echo.
6. Operation of the unit with the air filter removed.
7. Operation at engine speeds in excess of Echo recommendations.
8. Repair by an unauthorized party during the warranty period.
9. Normal wear and tear.
10. Operation of the unit with an incorrect fuel/oil ratio

ECHO MAKES NO FURTHER EXPRESS WARRANTIES OR REPRESENTATIONS EXCEPT THOSE CONTAINED HEREIN. NO REPRESENTATIVE OR DEALER IS AUTHORIZED TO ASSUME ANY OTHER LIABILITY REGARDING LITTLE WONDER PRODUCTS. THE DURATION OF IMPLIED WARRANTIES GRANTED UNDER STATE LAW, INCLUDING WARRANTIES OF MERCHANTABILITY AND FITNESS FOR A PARTICULAR PURPOSE ARE LIMITED IN DURATION TO THE DURATION OF THE EXPRESS WARRANTY GRANTED HEREUNDER. ECHO SHALL IN NO EVENT BE LIABLE FOR DIRECT, INDIRECT, SPECIAL OR CONSEQUENTIAL DAMAGES. SOME STATES DO NOT ALLOW LIMITATIONS ON HOW LONG AN IMPLIED WARRANTY LASTS, AND/OR DO NOT ALLOW THE EXCLUSION OR LIMITATION OF INCIDENTAL OR CONSEQUENTIAL DAMAGES, SO THE ABOVE LIMITATIONS AND EXCLUSIONS MAY NOT APPLY TO YOU. THIS WARRANTY GIVES YOU SPECIFIC LEGAL RIGHTS, AND YOU MAY ALSO HAVE OTHER RIGHTS WHICH MAY VARY FROM STATE TO STATE.

To validate this warranty, the original purchaser must complete and return within ten (10) days of the date of purchase the warranty registration card supplied with each unit.

For additional information regarding this warranty or service of Little Wonder products, you may contact Echo Incorporated at 3150 MacArthur Boulevard, Northbrook, Illinois 60062. Or call Toll Free 800-323-1478, in Illinois call 312-498-1390.

INSTRUCTIONS FOR SAFE OPERATION

1. READ CARE AND SAFETY INSTRUCTIONS CAREFULLY.
2. For fuel mixture and engine operation, read engine manual carefully. BEFORE STARTING BE SURE STOP SWITCH IS IN START POSITION.
3. DO NOT RUN ENGINE IN AN ENCLOSED SPACE. THE EXHAUST FUMES CAN BE LETHAL.

CARE AND SAFETY

1. READ AND FOLLOW ALL INSTRUCTIONS.
2. DRESS PROPERLY - Do not wear loose clothing or jewelry. They can be caught in moving parts. Use of sturdy gloves, non-skid footwear and safety glasses is recommended.
3. STAY ALERT - Watch what you are doing and use common sense. Do not operate unit when fatigued.
4. KEEP CHILDREN AND INCAPABLE PERSONS AWAY - Do not permit children to contact unit. Keep children a safe distance from work area. Never allow a person mentally ill, under influence of alcoholic drinks or drugs, or too young in age, to operate unit.
5. WARNING - Do not fuel, refuel or check fuel system when smoking or near an open fire. Do not run the engine when fueling or refueling. Stop engine when transporting from one place to another. Do not leave engine running unattended.
6. CAUTION — Do not start or run engine indoors as poisonous carbonmonoxides are emitted.
7. Do not use the unit when electric system causes spark outside the cylinder. Check spark plug from time to time. When checking, keep plug a safe distance from cylinder to avoid burning of evaporated fuel from cylinder.
8. MAINTAIN & EXAMINE ENGINE WITH CARE - Follow maintenance instructions and do not use if parts are defective or missing from engine.
9. STORE UNIT INDOORS - When not in use store unit indoors in a sheltered area (a dry place). The engine, as well as fuel, should not be stored in a house.
10. DO NOT ATTEMPT TO REPAIR ENGINE - Have repairs made by qualified dealer or repairman. See that only identical replacement parts are used.

SERVICE INFORMATION

Specifications

MODEL	SV-4	
Dry Weight	kg (lb.)	2.5Kg 5 lb. 10 ounces
Engine	KIORITZ, Air-cooled, two-stroke, single cylinder	
Rotation	Counterclockwise viewed from PTO	
Displacement	cc (cu. in.)	21.2 (1.294)
Bore x Stroke	mm (in.)	32.2 (1.268) x 26.0 (1.024)
Compression ratio	6.6:1	
Carburetor	ZAMA C1U	
Ignition	electronic ignition type CDI	
Starter	automatic rewind type	
Fuel	Premixed two-stroke fuel	
Mixing ratio	20:1 or a ratio approved by KIORITZ/ECHO	
Gasoline	Regular or unleaded	
Oil	ECHO air-cooled two-stroke oil or approved equiv.	
Fuel tank capacity	ℓ (US. fl. oz.)	17.5 fluid ounces 1.1 pint
Clutch	Centrifugal type	
Exhaust system	Spark arrester type	
Air cleaner	Felt type	

Technical Data

MODEL	SV-4	
Spark plug gap NGK-BM-6A Champion CJ-8	mm (in.)	0.6-0.7 (0.024-0.028)
Pole core gap	mm (in.)	0.3-0.4 (0.012-0.016)
Ignition timing	BTDC	25 BTDC
Secondary coil resistance	k Ω	1.0-2k Ω
Minimum secondary voltage	kV	15kV
High speed needle (H needle)	1 turn open \pm 1/4 turn	
Idle mixture needle (L needle)	1 turn open \pm 1/4 turn	
Idle speed adjusting screw	2 (Turn until it lightly touches throttle shaft and forward 2 turns)	
Idling speed	rpm	2500-3000
Operating speed	rpm	5000-8000
Compression pressure	kg/cm ² (psi)	6.0 (85)

WARNING: — When testing for spark, use proper testing equipment only. Failure to do so may cause permanent damage to CDI Module.