



# ASSEMBLY & OPERATING INSTRUCTIONS FOR SV2AE ENGINES

Thank you for your order of the MANTIS-20 Tiller/Cultivator. Your MANTIS-20 is a hard working yard and garden machine that will give you many, many years of satisfying service. We know you'll be delighted with its performance.

Please take a few minutes to read the instructions before assembling and operating your MANTIS-20. You'll have a better understanding of how the machine works and how to best put it to work in your garden.

Should you have any questions or problems with your MANTIS-20, please call us immediately at 1-800-366-6268 and speak with a customer service representative.

## UNPACKING

Remove all items from the carton, but **do not** remove the cardboard from around the tiller worm gear housing.

Lay out all the parts and inspect them carefully. Your MANTIS-20 is partially assembled and comes packed with the parts listed. The bag of hardware is located between the tines.

### INCLUDED IN THIS PACKAGE IS:

Qty.	Part name	Key #
1	Upper handle with Throttle	4
1	Upper handle without Throttle	5
2	Lower handles	6
1	Pair (Tilling/Cultivating) Tines	46/47
1	Assembly (engine, hood, transmission)	--
1	Cross bar handle brace	8
1	Bag hardware containing:	
	4 bolts (#11); 6 nuts (#12); 1 bolt (#23) 2 pins (#48)	
	1 bolt (#24); 2 clamps (#22); 1 clip (#15)	

Please read **all the instructions** before attempting to assemble or operate your MANTIS-20. You will need the following tools for assembly: Two 7/16" wrenches or two adjustable wrenches.

## ASSEMBLY

Using the cardboard packing material around the worm gear housing to stabilize your MANTIS-20, stand the worm gear housing and engine assembly up, and lay the attached handle parts to the side.

Suggestion: Install all nuts and bolts finger tight, until assembly is complete.

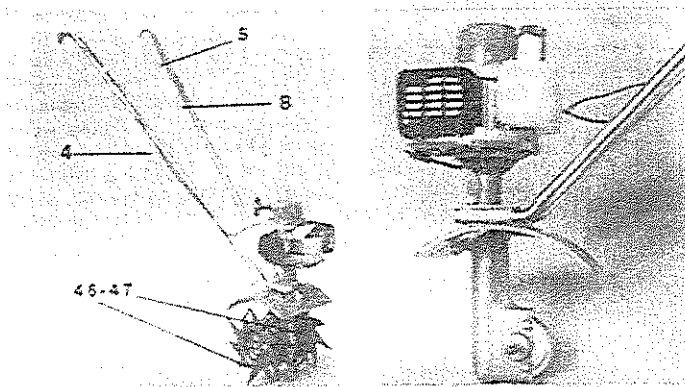

Secure lower handles (6) to worm gear housing in the recesses provided, located below the engine under the fuel tank. Place long bolt (23) through hole in handle clamp (22), then through inside hole in short leg of lower handle, through back channel provided in worm gear housing, through inside hole in short leg of opposite lower handle. Place the other handle clamp (22) on this side and add nut (12) finger tight. Repeat procedure with bolt (24) as above using front channel of worm gear housing. Tighten all nuts and bolts. NOTE: Gas tank should face you as you'd hold the handles in operation.

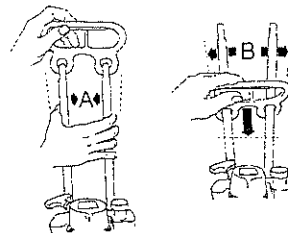

Lightly squeeze lower handles (6) towards one another so they line up with the two smaller holes on the carrying handle. Then slide the Mantis Carrying Handle over and down the lower handles to Point 'A' on the diagram. Gently pull lower handles back to their original position 'B'.

Install the upper handle (4), the one with the wire and throttle cable, to either side of the lower handle (which ever you prefer). Use the nut and bolt to secure it in position. Do the same for the other handle. Secure the throttle cable and ground wire in position on the lower handle using the extra throttle clip (15).

Install handle brace (8) using 7/16" wrench to tighten bolts (11) and nuts (12).

Remove the cardboard packing material from around the worm gear housing and insert the tines onto the drive shafts extending from either side of the worm gear housing. Secure the tine assembly to the shaft using the hair pins (48) provided.

## FUEL MIX

Your Mantis tiller is powered by a commercial two stroke, air cooled engine which requires a fuel mixture of gasoline and lubricating oil. Using a mixture of 50 parts unleaded regular gasoline and 1 part two stroke oil (50:1.) Use branded 89 octane (R+M+2) unleaded gasoline or gasohol (maximum 10% ethyl alcohol, no methyl alcohol.)

## STARTING A COLD ENGINE

Be sure that the fuel tank is filled with the correct mixture of gasoline and air cooled 2-cycle mixing oil.

Pull the ignition switch in "START" position. This switch is located on the handle near the throttle lever.

Shift the choke lever to closed position, (all the way forward). Pull the starter handle until the engine fires. Engine will pop or momentarily start and then stall. (Be sure not to flood engine.)

After the engine momentarily starts and stalls shift the choke shutter to fully open position (all the way back), **and start the engine again** and allow to warm up before using.

The engine will only run with the choke **fully open**.

**NOTE:** The decal on the choke housing is only for identification of parts on the carburetor. The "H and L" refers to the high and low screws. The "idle" refers to the idle screw location and NOT the position where the choke lever should be placed. The choke controls the amount of air, not the amount of gasoline that is drawn into the carburetor. Your MANTIS-20 has a centrifugal clutch. This means the tines will not turn while the engine is at normal idle. The tines will engage when you squeeze the throttle. (See photo on next page)

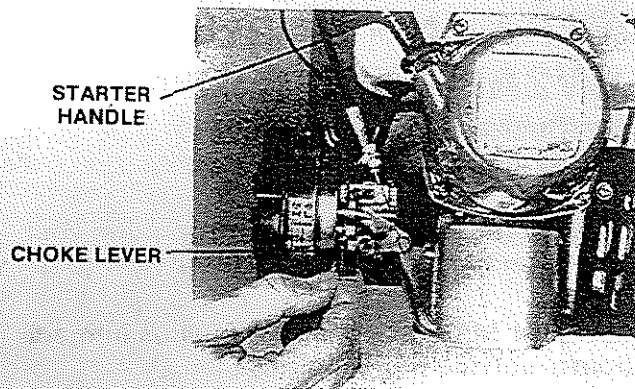

## HOW TO TELL THE DIFFERENCE BETWEEN THE TILLING POSITION OF THE TINES AND THE CULTIVATING POSITION OF THE TINES.

The tilling position will dig down in the soil 6 to 8 inches. The tines are set in this position when the **points** (straight edges) of the tines are impacting the soil directly. See photo.

The cultivating, slicing or weeding position will dig down in the soil only 2 to 3 inches. The tines are set in this position when the slanted edges of the tine blades are slicing the soil.

### STARTING A HOT ENGINE

Put the engine switch to the START position.

Open the choke. (All the way back.)

Pull starter rope to start engine.

If engine doesn't start within a couple of pulls, try using the cold start procedure.

If engine still does not start, check the spark plug for fouling or flooding.

#### Important

If you experience starting difficulties, DO NOT use starting fluids. Use of starting fluids will cause permanent engine damage and will void warranty.

If your MANTIS-20 engine does not start in 10-20 pulls, call our Customer Service Department.

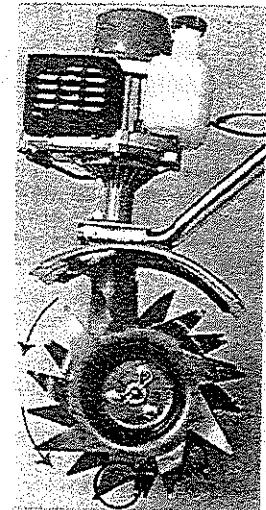
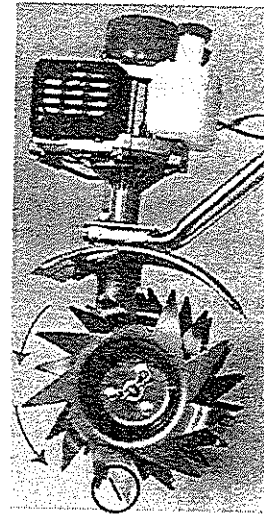

**TILLING POSITION**  
Points (straight edge) into the ground

**CULTIVATING POSITION**  
Slicing edge into the ground

To stop the engine, push the ignition switch to the stop position. Should the switch fail to operate properly, you can stop the engine by closing the choke. Before you put the MANTIS-20 away, let it run at idle giving the engine a chance to cool down.

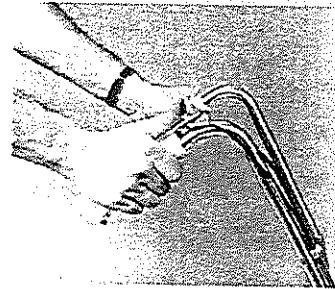

### GUIDELINES FOR OPERATION

Carry the MANTIS-20 to your garden. It has no wheels that roll. The tines will not turn unless the engine is on and the throttle engaged. After starting the engine, let it warm up for a minute or two.

While in the ground, the MANTIS-20 will work itself forward. For maximum tilling and cultivating action, **gently pull the MANTIS-20 backwards towards you**. Soon you will learn the right pull for your needs and garden soil.

When you get to the end of the row, pull the MANTIS-20 backward down the entire row. Your footprints will disappear and your seedbed will be ready for planting.

After warm-up, you can begin working with your MANTIS-20 by squeezing the throttle lever. Your MANTIS-20 will begin operating when the engine reaches about 3,000 RPM. This is due to the centrifugal clutch in the engine which **ONLY ENGAGES** your MANTIS-20 and its attachments **AT SPEEDS HIGHER THAN IDLE**.

Your MANTIS-20 engine may keep on running even if the **attachment** you are using becomes jammed, entangled, or overloaded. If your MANTIS-20 becomes jammed, entangled, or overloaded, **shut off the engine immediately** and remove the obstruction from the attachment (you might find it easier to first remove the attachment from the tiller depending on the kind of obstruction). **NEVER ATTEMPT TO REMOVE AN OBSTRUCTION WHILE THE ENGINE IS RUNNING. SERIOUS INJURY CAN RESULT.** Once the obstruction has been removed, the engine can be re-started as normal.

### WORM GEAR HOUSING

The MANTIS-20 worm gear housing has been lubricated at the factory and should provide years of satisfactory service with no additional attention. Once a year, it is a good idea to inspect the lubricant level in the worm gear housing. To do this, remove the worm gear housing cover plate and clean. The **GREASE LEVEL INSIDE THE WORM GEAR HOUSING SHOULD BE NEAR THE TOP OF THE HOUSING**. If it isn't, top it off with lithium #0 grease or equivalent. **DO NOT OVERFILL**. This can create pressure which can cause seals to fail. Do not use the grease fitting for filling.



### STORING YOUR MANTIS-20

Drain the gas tank and then run the engine until it stops. After draining the fuel, remove the spark plug and pour about a teaspoonful of clean air cooled 2-cycle oil through the spark plug hole into the combustion chamber. Slowly pull the starter 3-4 times to coat the interior of the cylinder wall. Inspect the spark plug (Champion CJ-8), clean (or replace) and re-install.

If you have fuel left over at the end of the gardening season, discard it rather than save it for use next spring. Clean out the air cleaner as shown in the manual. Clean the entire machine of dirt, grass, etc. and wipe the tines with oil or spray with WD-40 to prevent rusting. Oil throttle cable and all moving parts that are visible (do not remove engine cover). Check grease level in transmission and refill if necessary. Order any new parts that are badly worn or broken (even though you may have been "living with" the inconvenience all summer). Put your Mantis away in a clean, dry place for the winter.

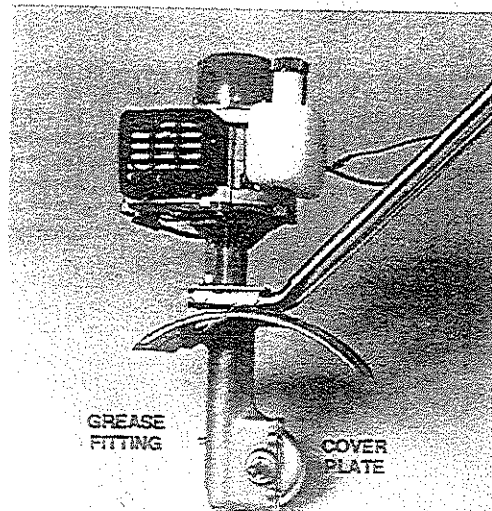

## AIR FILTER

A clogged air filter can seriously affect the performance, operating temperature, and lubrication of a 2-cycle engine. For these reasons, the air filter should be cleaned prior to each use, or when working for prolonged periods in a dusty environment. Dust and dry dirt are easily removed from the filter elements. Filters can also be washed in gasoline, if needed, to remove oil build-up. The sponge filters of the MANTIS-20 are dry filters. THEY DO NOT NEED OILING AFTER CLEANING.

To remove and clean air filter sponges, proceed as follows:

- a. Pull off the retainer "C" clip from around the filter housing.
- b. Peel off the black holder by pulling on the small tab.
- c. Remove the black louvered cover and take out the two air filter sponges.
- d. Clean and re-install IN THE REVERSE ORDER. Make sure that the positioning "key" on the louvered cover is in the slot at the top of the air filter housing.

### Air filter disassembly

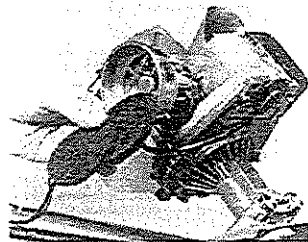
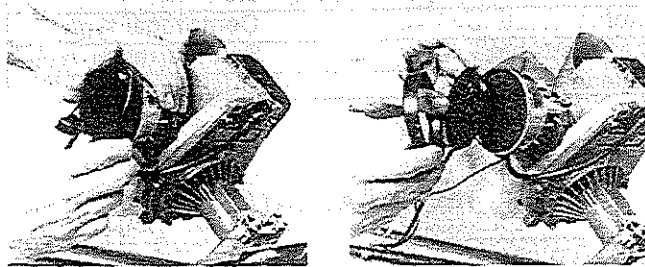

## LIFETIME TINE REPLACEMENT

Because few gardeners can believe that such a small machine will do so many BIG jobs...we warrant the tilling/cultivating tines forever. If any tine breaks in normal usage—ever—just send the broken tine back to us and WE'LL REPLACE IT FREE OF CHARGE.

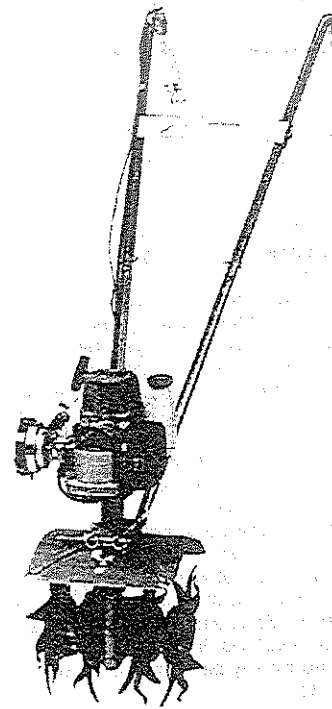

## LIMITED WARRANTY INFORMATION MANTIS-20 TILLER

Mantis extends only to the original consumer purchaser a limited warranty against defects in material and workmanship for: a period of two years when used exclusively for personal, family, or household purposes; or a period of ninety days when used for commercial purposes. This warranty covers all portions of the MANTIS-20 Tiller product except the engine, which is warranted separately by the engine manufacturer.

MANTIS will repair or, at its option, replace any defective part or parts of the product free of charge. In the event of a defect or malfunction, the purchaser must send the product, postage prepaid, to Warranty Department, Mantis, 1028 Street Road, Southampton, PA 18966.

MANTIS assumes no responsibility in the event that the product: was assembled or used in contravention of any assembly, care, safety, or operating instructions contained in the consumer brochure; was not used with reasonable care; or was used for other than normal and intended purposes.

MANTIS MAKES NO EXPRESS WARRANTIES OR REPRESENTATIONS EXCEPT THOSE CONTAINED HEREIN. THE DURATION OF ANY IMPLIED WARRANTY, INCLUDING MERCHANTABILITY AND FITNESS FOR A PARTICULAR PURPOSE, IS LIMITED TO THE DURATION OF THE EXPRESS WARRANTY. MANTIS DISCLAIMS ALL LIABILITY FOR INDIRECT AND/OR CONSEQUENTIAL DAMAGES, SOME STATES DO NOT ALLOW LIMITATIONS ON HOW LONG AN IMPLIED WARRANTY LASTS AND/OR DO NOT ALLOW THE EXCLUSION OR LIMITATION OF INCIDENTAL OR CONSEQUENTIAL DAMAGES, SO THAT ABOVE LIMITATIONS AND EXCLUSIONS MAY NOT APPLY TO YOU. THIS WARRANTY GIVES YOU SPECIFIC LEGAL RIGHTS, AND YOU MAY HAVE OTHER RIGHTS WHICH VARY FROM STATE TO STATE.

MANTIS  
1028 STREET ROAD  
SOUTHAMPTON, PA 18966  
TELEPHONE #215-355-9700

## ECHO INCORPORATED

### Mantis-20 Ninety Day Limited Engine Warranty

Echo Incorporated, referred to hereafter as Echo, warrants to the original purchaser at resale that each new MANTIS-20 Tiller engine, throttle and clutch shall be free from defects in material and workmanship for a period of ninety (90) days from the date of the original purchase. In the event of a defect in the MANTIS-20 Tiller engine, throttle and clutch, Echo will repair and/or replace the defective part or parts free of charge. This applies only to the engine, throttle and clutch.

In the event of a malfunction or failure in a MANTIS-20 Tiller engine, throttle and clutch, simply deliver or send, postage prepaid, within the warranty period of ninety (90) days, the complete product to your nearest authorized Echo dealer. Echo reserves the right to inspect the claimed defective part or parts to determine if the defect or malfunction complained of is covered by this warranty. Upon confirmation that the malfunction or failure is the result of a defect covered by this warranty, Echo shall, within ninety (90) days after receipt of the product, at its option, repair and/or replace the defective part or parts free of charge.

Authorized Echo dealers are located throughout the United States and Canada to assure fast and efficient service to your MANTIS-20 Tiller product. If you do not know the location of an authorized Echo dealer, you can obtain such information by contacting Echo at the address listed below. Echo assumes no responsibility for any damage, defects, or costs resulting from repairs and/or modifications of a product performed by any person who is not an authorized servicing dealer or distributor.

This warranty shall only cover defects arising under normal usage. Echo assumes no responsibility whatsoever if the MANTIS-20 Tiller product shall fail during the warranty period by reason of:

1. Misuse, negligence, physical damage or accident.
2. Lack of maintenance as prescribed in the Owner's Manual.
3. Improper adjustments of ignition, timing and carburetors.
4. The use of fuels and lubricating oils not approved by Echo.
5. The use of parts or accessories not approved by Echo.
6. Operation of the unit with the air filter removed.
7. Operation at engine speeds in excess of Echo recommendations.
8. Repair by an unauthorized party during the warranty period.
9. Normal wear and tear.
10. Operation of the unit with an incorrect fuel/oil ratio.

ECHO MAKES NO FURTHER EXPRESS WARRANTIES OR REPRESENTATIONS EXCEPT THOSE CONTAINED HEREIN. NO REPRESENTATIVE OR DEALER IS AUTHORIZED TO ASSUME ANY OTHER LIABILITY REGARDING MANTIS-20 TILLER PRODUCTS. THE DURATION OF IMPLIED WARRANTIES GRANTED UNDER STATE LAW, INCLUDING WARRANTIES OF MERCHANTABILITY AND FITNESS FOR A PARTICULAR PURPOSE ARE LIMITED IN DURATION TO THE DURATION OF THE EXPRESS WARRANTY GRANTED HEREUNDER. ECHO SHALL IN NO EVENT BE LIABLE FOR DIRECT, INDIRECT, SPECIAL OR CONSEQUENTIAL DAMAGES. SOME STATES DO NOT ALLOW LIMITATIONS ON HOW LONG AN IMPLIED WARRANTY, AND/OR DO NOT ALLOW THE EXCLUSION OR LIMITATION OF INCIDENTAL OR CONSEQUENTIAL DAMAGES, SO THE ABOVE LIMITATIONS AND EXCLUSIONS MAY NOT APPLY TO YOU. THIS WARRANTY GIVES YOU SPECIFIC LEGAL RIGHTS, AND YOU MAY ALSO HAVE OTHER RIGHTS WHICH MAY VARY FROM STATE TO STATE.

For additional information regarding this warranty or service of MANTIS-20 Tiller products, you may contact Echo Incorporated at 400 Oakwood Road, Lake Zurich, Illinois 60047 - (312-540-8400), or MANTIS, 1028 Street Road, Southampton, PA 18966 - (215-355-9700).

## SPECIFICATIONS

Dry Weight	kg(lb.)	3.2 (7.0)
Engine	ECHO, Air-cooled, two-stroke, single cylinder, (SV-2AE)	
Rotation	Counterclockwise viewed from PTO	
Displacement	cc (cu.in.)	21.2 (1.294)
Bore x Stroke	mm (in.)	32.2 (1.268) x 26.0 (1.024)
Compression ratio	6.5:1	
Carburetor	WALBRO diaphragm, model WA type	
Ignition	Electronic ignition type CDI	
Starter	Automatic rewind type	
Fuel	Premixed two-stroke fuel	
Mixing ratio	50:1 mixture	
Gasoline	89 Octaine	
Oil	ECHO air-cooled two-stroke oil or approved equiv.	
Fuel tank capacity	ℓ (US. fl. oz.)	0.5 (16.9)
Clutch	Centrifugal type	
Exhaust system	Spark arrester type	
Air cleaner	Dual element	

## TECHNICAL DATA

Spark plug gap	mm (in.)	0.6-0.7 (0.024-0.028)
Pole core gap	mm (in.)	0.3-0.4 (0.012-0.016)
Ignition timing	30 BTDC	
Primary coil resistance	0.2 Ω	
Secondary coil resistance	1.5-3k Ω	
Excitor coil resistance	120-200k Ω	
Minimum secondary voltage	15kV	
High speed needle (H needle)	1 turn open ± ¼ turn	
Idle mixture needle (L needle)	1 turn open ± ¼ turn	
Idle speed adjusting screw	2 (Turn until it lightly touches throttle shaft and forward 2 turns)	
Idling speed	rpm	2500-3000
Operating speed	rpm	5000-8000
Compression pressure	kg/cm <sup>2</sup> (psi)	6.0 (85)

### WARNING:

When testing for spark, use proper testing equipment only. Failure to do so may cause permanent damage to CDI Module. (Capacitor Discharge Ignition.)

## SV-2A & SV-2AE

Key No.	Part Number	Description	Qty.
1	900242 04020	Screw 4x20	9
* 2A	177200 05920	Starter assy (WR) consisting of item 2 thru 8	1
2	177209 05920	Case, starter (WR)	1
3	177227 05330	Guide, rope	1
4	177221 05020	Plate, starter	1
5	177220 03930	Spring, rewind	1
6	177206 05020	Drum, starter	1
7	177226 03930	Rope, starter	1
8	177228 11130	Grip, starter	1
9	177214 04630	Washer	1
10	900241 04010	Screw 4x10	1
11	100615 04630	Gasket, starter	1
12	177217 04630	Screw, pawl	2
13	177247 04630	Spacer, ratchet	2
14	177218 03930	Pawl, starter	2
15	177234 04632	Spring, return	2
16	900502 00008	Nut 8 (3N)	1
17	900605 00008	Washer, spring 8	1
18	100143 04630	Washer	1
SV-2A ONLY } 19	156200 04631	Flywheel	1
20	900242 04010	Screw	13
SV-2A ONLY } 21	156127 04521	Condenser	1
22	156134 04630	Pad, lubrication	1
23	156101 04630	Points, breaker	1
24	156126 04630	Coil, ignition	1
25	900242 04025	Screw 4x25	2
29	100212 04630	Oilseal	1
SV-2A ONLY } 30 A&B	100200 05020	Crankcase set	1
31	151112 04630	Bushing	1
32	100215 03930	Pin, Dowel	2
33	900810 36201	Bearing, ball 6201	2
34	100142 00310	Key (M)	1
35	100100 05331	Crankshaft assy	1
36	610325 02730	Key, woodruff	1
37	100242 04630	Gasket, crankcase	1
38	900702 00032	Circlip (CR-32)	1
39	100212 03930	Oilseal	1
40	900242 05030	Screw 5x30	4
42	175012 03930	Bearing, needle	1
43	100015 04630	Circlip, piston pin	2
44	100013 10210	Pin, piston	1
45	100010 05330	Piston	1
46	100011 05330	Ring, piston	2
47	101010 04630	Gasket, cylinder base	1
48	900242 05020	Screw 5x20	4
49	101011 05020	Cylinder	1
50	101014 05330	Stud, muffler	2
51	101514 05920	Cover, cylinder (BLK)	1
52	159010 00330	Plug, spark (BM-6A)	1
53	159011 00510	Coil, spark plug cap	1
54	159012 01620	Cap, spark plug	1
56	900603 00005	Washer 5	2
57	145510 05020	Gasket, muffler	1
58	145806 05120	Muffler (A)	1
59	145807 05120	Muffler (B)	1
60	145866 05120	Gasket, muffler lid	1
61	145861 05920	Lid, muffler	1
62	433020 00830	Locknut 5	3
63	145621 05921	Cover, muffler	1
64	145862 05120	Screen, muffler (SAM)	1
65	145863 05120	Holder, screen (SAM)	1
66	900610 00004	Washer (TWA-4)	2
67	900220 04008	Screw 4x8	2
68	130010 05020	Gasket, carburetor	1
69	130017 05020	Insulator	1
70	130016 06430	Gasket, carburetor	1
* 71A	123000 08430	Carburetor (WA-59) (see carburetor assembly parts breakdown)	1

Key No.	Part Number	Description	Qty.
74	178021 07330	Locknut	1
75	900602 00006	Washer 6	1
76	900502 00006	Nut 6 (3N)	1
77	178001 04520	Cable throttle	1
80	900600 00005	Washer 5	3
81	900605 00005	Washer, spring 5	3
82	130021 05020	Bolt	2
86	178024 06130	Bracket, throttle	1
87	178110 05330	Screw	1
88	900220 05025	Screw 5x25	1
89	900500 00005	Nut 5	1
90	178010 05330	Control, throttle	1
91	178043 05230	Spring, throttle return	1
94	890154 03930	Label, fuel mix	1
* 95A	131004 04520	Cap assy fuel, consisting of 94 thru 98	1
95	131017 04930	Cap fuel, (BLK)	1
96	-131314 00330	Valve, check	1
97	-131015 04520	Holder, check valve	1
98	-131016 04930	Gasket, fuel tank cap	1
99	131010 05920	Tank, fuel	1
100	131910 05020	Bracket, fuel tank	1
101	131924 05921	Cushion	1
103	131205 07320	Strainer, fuel	1
104	-132115 04920	Grommet	1
105	132007 05920	Pipe, fuel w/grommet	1
108	101500 05020	Fan assy, cooling	1
109	175018 05130	Spring, clutch	2
110	175009 05130	Shoe, clutch	2
111	175019 04630	Plate, clutch	1
112	175015 05020	Washer, clutch	1
113	900808 36000	Bearing, ball 6000	1
114	175044 04630	Washer, clutch	1
115	175010 04632	Drum, clutch	1
116	175014 04630	Washer, clutch	1
117	900105 06010	Bolt, h.s. 6x10	1
118	101511 05920	Cover, fan (WR)	1
119	159015 04630	Cover, plug cap	1
120	178121 04520	Clip	1
121	163400 02160	Switch, ignition	1
122	163810 05920	Bracket, switch	1
124	900115 05025	Bolt 5x25	1
125	130016 06230	Gasket, carburetor	1
126	130307 05922	Case, air cleaner	1
* 126A	130300 00761	Air cleaner assy, consisting of 125 thru 132	1
127	890158 00760	Label, caution	1
128	130425 00761	Holder, cover	1
129	130319 00760	Grid, air cleaner	1
130	130310 00760	Filter, air	2
131	130313 04620	Cover, air cleaner	1
132	130341 04620	Holder, air cleaner	1

### SV-2AE ONLY

Key No.	Part Number	Description	Qty.
19	156800 06331	Flywheel	1
24	156627 09820	Coil, exciter	1
31	156114 06330	Bushing	1
135	159310 09820	Bracket, ignition coil	1
136	900242 05010	Screw 5 x10	1
137	159113 23630	Clip	1
138	156601 09820	C. D. Ignition module	1
139	900242 04018	Screw 4x18	2
140	162021 09820	Lead, ground	1

# MANTIS-20 PARTS LAYOUT

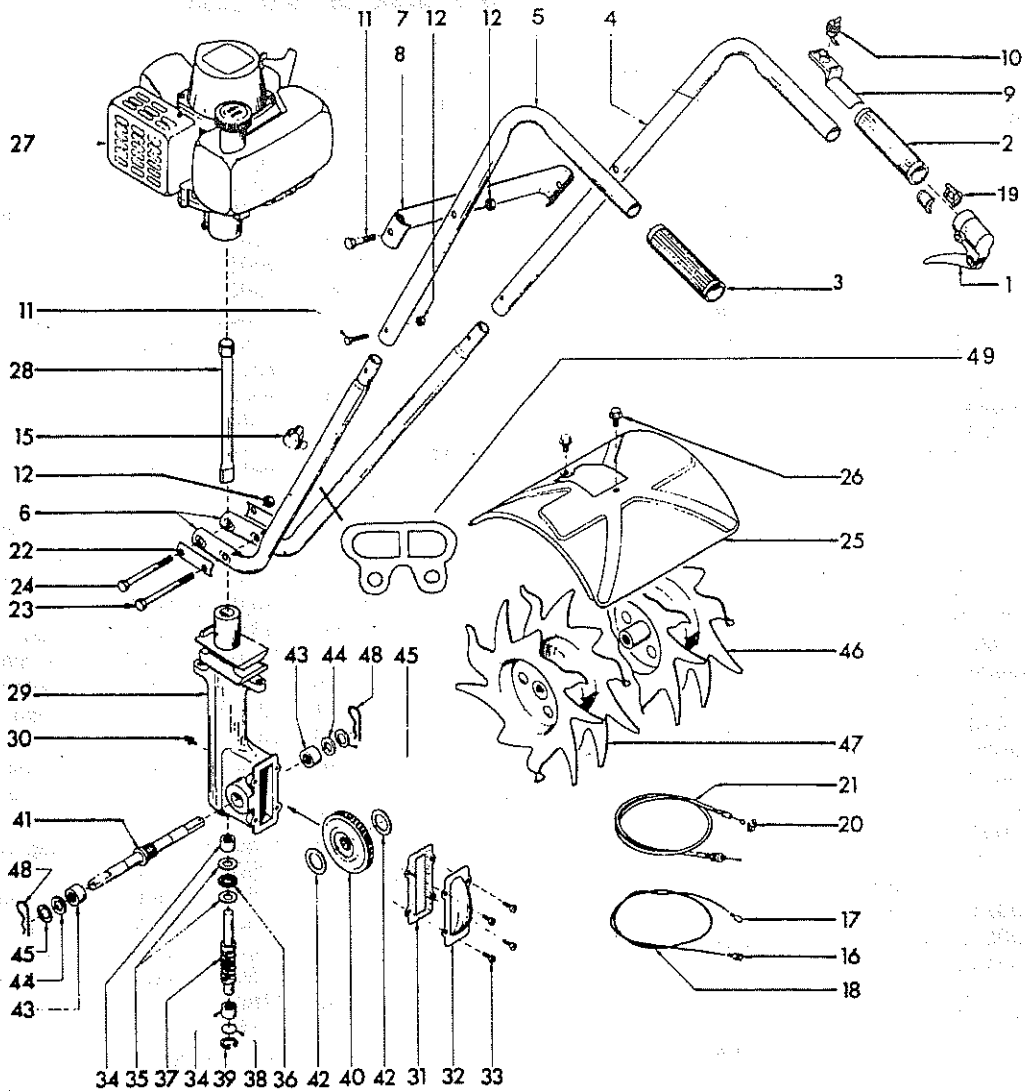

KEY NUMBER	PART NUMBER	QTY. UNIT	DESCRIPTION	KEY NUMBER	PART NUMBER	QTY. UNIT	DESCRIPTION
1	382	1	Throttle Lever	26	140	2	Bolt 1/4-20 x 1/2" Lg.
2	383	1	Grip-Thru	27	380E-4B	1	Engine
3	619	1	Grip	28	468	1	Drive Shaft
4	4062	1	Upper Handle with Throttle	29	466	1	Worm Gear Housing
5	4061	1	Upper Handle without Throttle	30	127	1	Grease Fitting
6	4063	2	Lower Handle	31	436	1	Gasket
7	488M	1	Label	32	437A	1	Housing Cover
8	148	1	Handle Brace	33	651	4	Rd. Hd. Self Tapping Screw
9	464	1	Switch Bracket	34	423	2	Roller Bearing
10	479	1	Switch	35	425	2	Worm Bearing Race
11	410	4	Cap Screw 1/4-20 x 1" Lg.	36	424	1	Worm Thrust Bearing
12	972	6	Lock Nut 1/4-20	37	422	1	Worm Shaft
15	478	2	Throttle Clip	38	426	1	Worm Disc
16	477	1	Connector Female	39	428	1	Retaining Ring
17	476	1	Connector Male	40	429	1	Worm Gear
18	4075	1	Ground Wire	41	431	1	Tiller Wheel Shaft
19	379	1	Cable Retainer	42	430	2	Worm Gear Thrust Washer
20	413	1	Retaining Ring	43	432	2	Worm Gear Bearing
21	467-2	1	Throttle Cable Assy. (SV-2AE)	44	434	2	Bearing Seal
22	377	2	Handle Clamp	45	435	2	Bearing Seal Retainer
23 & 24	470	1	Long Bolt 1/4-20 x 3" Lg.	*46	438LA	1	Tiller Wheel Assy. L.H.
25	465	1	Fender Guard	*47	438RA	1	Tiller Wheel Assy. R.H.
				48	418-1	2	Tiller Wheel Retaining Hair Pin
				49	402	1	Plastic Carry Handle

\*NOTE: The tine assembly is only sold as a set they are not sold separately.



# SV-2AE PARTS LAYOUT

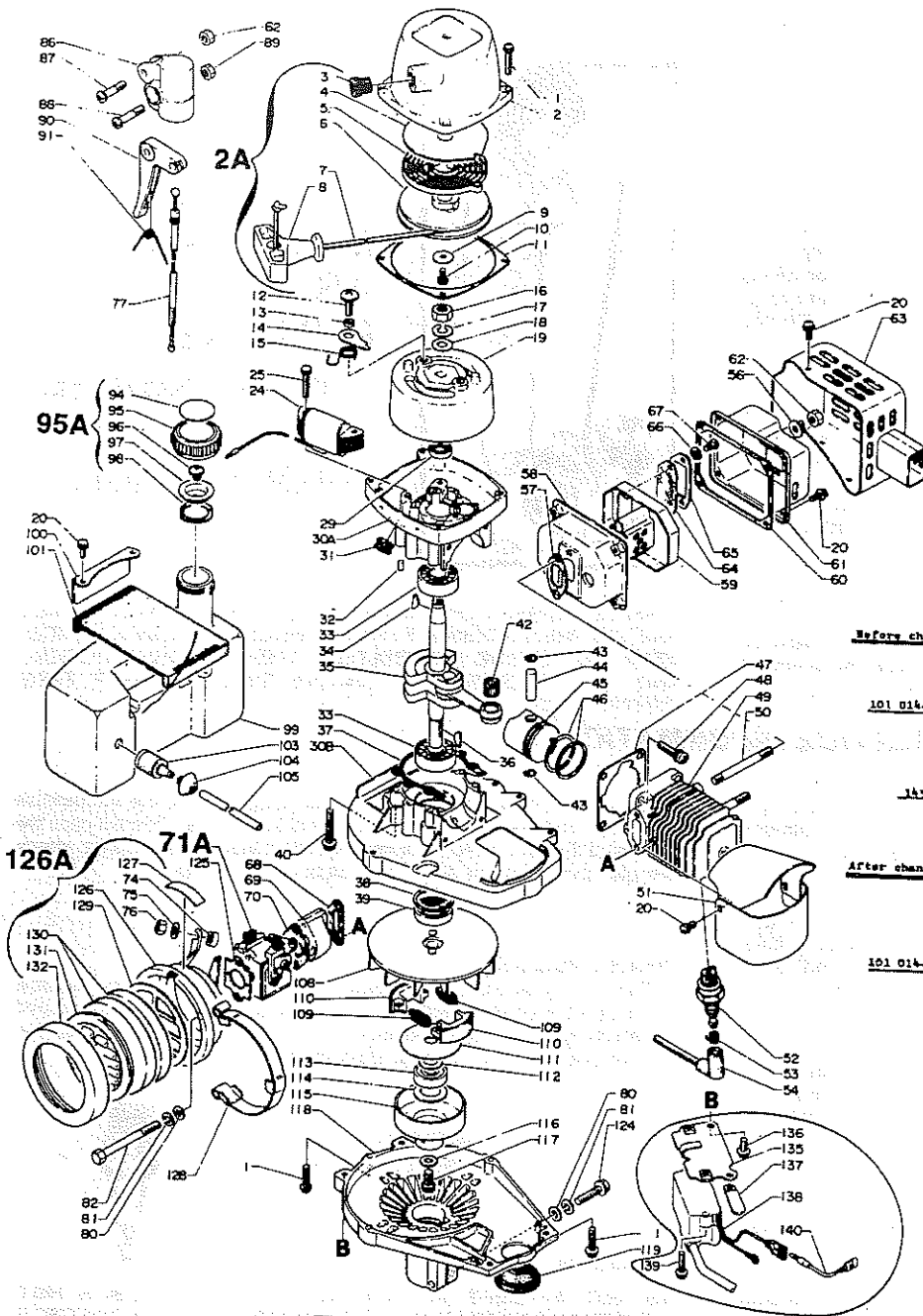

## MUFFLER MODIFICATION 3-27-84

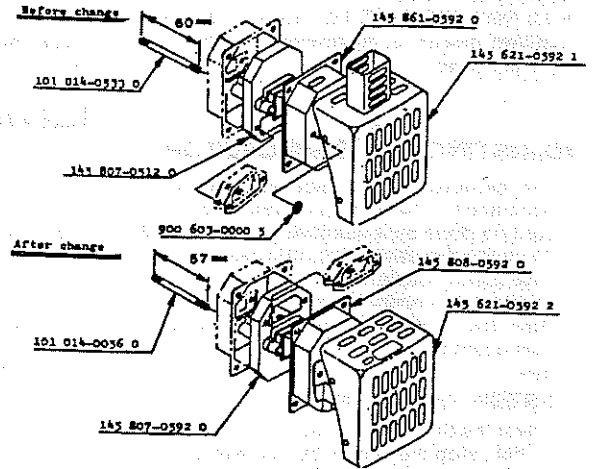

## CAPACITOR DISCHARGE MODULE ASSEMBLY

## CARBURETOR ASSEMBLY

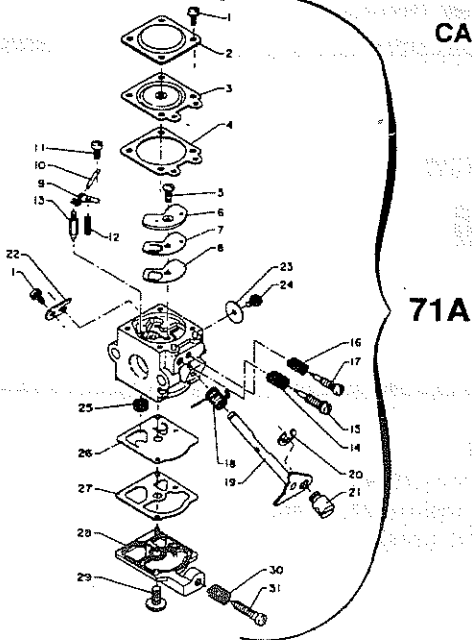

Key No.	Part Number	Description	Qty.
71A	123000 08430	Carburetor (WA-59) consisting of 1 thru 31	1
1	-123144 03930	Screw	5
2	-123142 03930	Cover, m. diaphragm	1
3	-123141 03930	Diaphragm, metering	1
4	-123140 03930	Gasket, m. diaphragm	1
5	-123167 05230	Screw, circuit plate	1
6	-123166 03930	Plate, circuit	1
7	-123165 03930	Diaphragm, circuit	1
8	-123164 03930	Gasket, circuit plate	1
9	-123123 03930	Lever, metering	1
10	-123138 03930	Pin, metering lever	1
11	-123139 03930	Screw, m. lever pin	1
12	-123122 03930	Spring, meter. lever	1
13	-123137 03930	Valve, inlet needle	1
14	-123119 03930	Spring, needle	1
15	-123120 06530	Needle, high speed	1
16	-123121 03930	Spring, needle	1
17	-123118 04420	Needle, idle	1
18	-123113 03930	Spring, throttle return	1
19	-123117 05020	Shaft, throttle	1
20	-123127 10630	Retaining, spring	1
21	-123172 04320	Swivel	1
22	-123127 03930	Clip, throttle shaft	1
23	-123116 05230	Valve, throttle	1
24	-123114 03930	Screw, throttle valve	1
25	-123126 03930	Screen, inlet	1
26	-123112 03930	Diaphragm, fuel pump	1
27	-123125 03930	Gasket, fuel pump	1
28	-123124 05020	Cover, fuel pump	1
29	-123110 03930	Screw, pump cover	1
30	-123133 11130	Spring, idle adjust	1
31	-123134 06530	Screw, idle adjust	1

## CARE AND SAFETY

READ AND FOLLOW ALL INSTRUCTIONS

- **DRESS PROPERLY** - Do not wear loose clothing or jewelry. They can be caught in moving parts. Use of sturdy gloves, non-skid footwear and safety glasses is recommended.
- **STAY ALERT** - Watch what you are doing and use common sense. Do not operate unit when fatigued.
- **KEEP CHILDREN AND INCAPABLE PERSONS AWAY** - Do not permit children to contact unit. Keep children a safe distance from work area. Never allow a person mentally ill, under influence of alcoholic drinks or drugs, or too young in age, to operate unit.
- **WARNING** — Do not fuel, refuel or check fuel system when smoking or near an open fire. Do not run the engine when fueling or refueling. Stop engine when transporting from one place to another. Do not leave engine running unattended.
- **CAUTION** — Do not start or run engine indoors as poisonous carbon monoxide is emitted.
- Do not use the unit when electric system causes spark outside the cylinder. Check spark plug from time to time. When checking, keep plug a safe distance from cylinder to avoid burning of evaporated fuel from cylinder.
- **MAINTAIN & EXAMINE ENGINE WITH CARE** - Follow maintenance instructions and do not use if parts are defective or missing from engine.
- **STORE UNIT INDOORS** - When not in use store unit indoors in a sheltered area (a dry place). The engine, as well as fuel, should not be stored in a house.
- **DO NOT ATTEMPT TO REPAIR ENGINE** - Have repairs made by qualified dealer or repairman. See that only identical replacement parts are used.

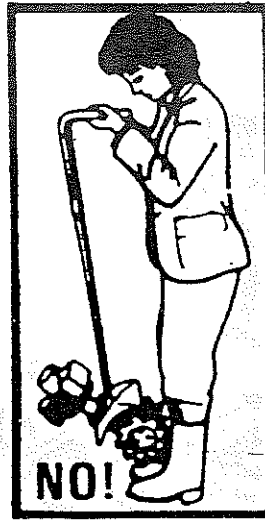

**DO NOT HOLD  
OR CARRY  
MANTIS-20  
AS IN THE  
PICTURE. IF  
TINES ENGAGE  
YOU CAN BE  
BADLY HURT.**

NEVER DEPRESS THROTTLE FOR FULL SPEED UNLESS TINES ARE ON THE GROUND. IF TINES SHOULD BECOME JAMMED, STOP THE ENGINE IMMEDIATELY, FREE THE OBSTRUCTION, AND - IF NECESSARY - REMOVE TINES TO HELP FREE OBSTRUCTION

## SERVICE INFORMATION

### ADJUSTING THE CARBURETOR

The carburetor has been adjusted at the factory for optimum performance. Should the carburetor require adjusting, this adjustment should be done by a qualified servicing dealer or mechanic.

To adjust the carburetor, proceed as follows:

- Low-speed needle valve (L) .....  $1 \pm \frac{1}{4}$  turn
- High-speed needle valve (H) .....  $1 \pm \frac{1}{4}$  turn

Turn the corresponding adjusting screw lightly clockwise to fully closed position and return the screw by the number of turns indicated above.

### TO STOP THE ENGINE

Lower the throttle lever and idle the engine for 3-5 minutes to cool it off. Then, stop the engine by depressing the stop switch. Stop switch and the engine are connected by a grounding lead wire, to ensure the functioning of the stop switch. If the stop switch doesn't work properly, check the grounding wire connection.

### STORING

If the unit is to be stored for a long period of time, drain fuel completely from tank. Fuel stored under the most ideal conditions may start to go stale in 30 days. Stale fuel has a high gum content which can clog carburetor and restrict the fuel flow.

Start engine and allow to run until it stops. Choke and restart engine to make sure all fuel has been used from the carburetor. This prevents formation of gum deposits. Remove the spark plug. Pour about a

teaspoonful of clean oil through the spark plug hole into the combustion chamber. Pull the starter handle slowly at least twice. This will coat the interior of the combustion chamber with oil. Clean the spark plug, check the gap and place the spark plug back in the engine.

### SPARK PLUGS

Clean or replace the plug if fouled with oily black deposits. Replace the plug if the center electrode is rounded at the end, or if the ground electrode is worn. Adjust the gap 0.6-0.7mm (.024-.028"). CAUTION— Do not over tighten the plug. Correct torque = 18-22 lbs. ft.

REPLACE WITH  
CHAMPION CJ-8

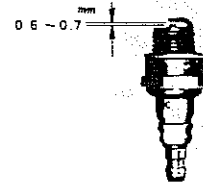

### CAUTION

DO NOT ATTEMPT TO REMOVE THE PLUG FROM A HOT ALUMINUM CYLINDER HEAD IN ORDER TO AVOID POSSIBLE DAMAGE TO THE THREADS.

**For Customer Service  
Call 1-800-366-6268  
9 AM to 5 PM ET**



**Mantis**  
1028 Street Road  
Southampton, PA 18966  
(215) 355-9700

P/N 385 M  
©Mantis 7/95